

# SAN JOSE SCALE MODELERS

P.O. Box 1052  
Cupertino, CA 95015

SCALE-FEET  
0 1 2 3 4 5 6 7 8 9 10

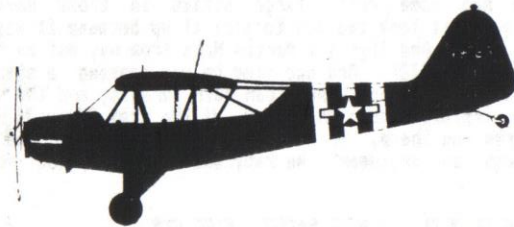
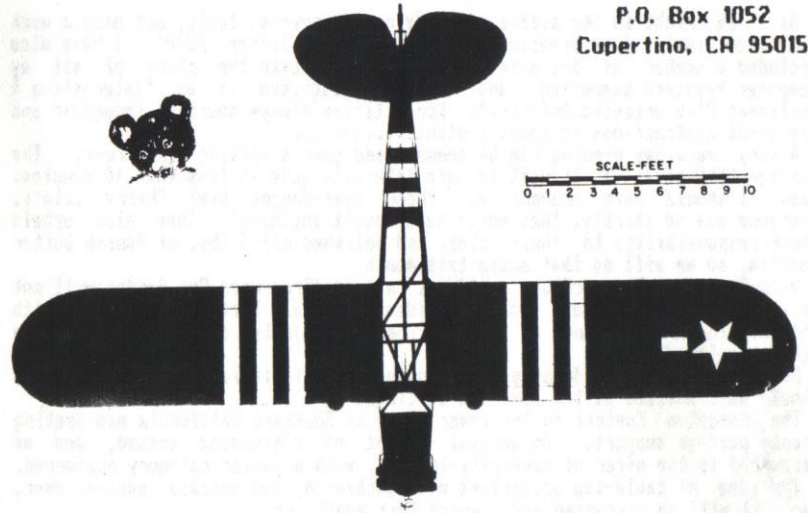

**JUNE 1988**

**Next Meeting: June 17, 1988; Friday**

**Meeting Time: 7:30 PM - Gab, Shop,  
8:00 PM - Business, Raffle**

**Location: Mercury Savings Meeting Room  
19376 Stevens Creek Blvd. Cupertino**

San Jose Scale Modelers  
P.O. Box 1052  
Cupertino, CA 95015



FIRST CLASS MAIL

Cliff Kranz \*\*B901  
3616 Hoover St.  
Redwood City, CA 94063



OFFICIAL  
IPMS/USA  
COMPLAINT  
FORM

PLEASE WRITE YOUR  
COMPLAINT IN BOX BELOW  
WRITE LEGIBLY



**IMPORTANT: Check the Year/Month code  
following "your name #" for the month  
your dues expire after. Renewal \$10.**



## MAY MINUTES

As I am right in the middle of studying for several tests, and only a week away from finals, I am breezing through this newsletter ASAP! I have also included a number of pre-printed information to take the place of all my computer keyboard hammering, and cleverly disguised it as "Interesting & Pertinent Club Oriented Articles". Long titles always sound so important and are great distractions to inept content.....so.....

A very warm May evening saw 54 members and guests filling the room. The sixteen COLD sodas I brought in were literally gone in less than 10 minutes. Damn! I should have brought all those over-bought Diet Cherry Cola's. Everyone was so thirsty, they would have bought anything! They also upheld their responsibility to their club, and polished off 3 lbs. of Danish Butter Cookies, so we will do that again this month.

Vice-President Eric McClure could not attend (Treasurer Rex Barden will not be able to attend the next two). President Bauer was back from France with photos. There were plenty of "Procrastination Projects" on display along with other completed models.

Moffet Field Airshow details were brought up, but little was known. Details should be finalized at the next two meetings.

The OrangeCon Contest in the lower state of Southern California was seeking trophy package support. An unusual amount of discussion ensued, and we succumbed to the offer of publicity for \$35, with a junior category preferred.

The idea of table-top protectors was touched-on, and quickly passed over. Maybe it will be discussed and ignored this month too.

After our break, we held our display raffle and then our high-buck raffle. We had just over \$70 of merchandise with a quality, fluorescent desk/work lamp and Tri-Tool saws, and sanding sticks, plus another of the Foreign Affairs Defense Annual. Thanks to Ron VanDerGrift, both for bringing his enjoyable presence all the way from Monterey, but also for hawking raffle tickets on the floor. We took in \$77 on the raffle. It is not supposed to make money, so we will have EVEN MORE PRIZES THIS MONTH. Thanks again to Daryl at D&J Hobby for his discounts on raffle purchases and last month's FREE F-20 Tigershark offer.

Then our guest speaker, William Hargraves, spoke to us and showed many unique pictures. He entertained us with military service stories, such as landing seaplanes at remote bases and trading such simple items as pencils for quarts of quality rum, and getting picked up immediately upon arrival by a jeep, even before the bigwig's staff car arrived, because he would bring in fresh eggs...said he had some pretty large steaks in those days. Also lobsters that were so big it took two men to pick it up because it was too big around for one man's hand! And flying a Martin Mars from way out in the South Pacific to New York, ...NON-STOP. And one time he was cooking a steak in the galley of a Mars while over South American rain forests, and the smell was drifting through the airplane. More and more of the crew "dropped in", when he noticed ALL the crew was there. NO ONE was in the cockpit, it was on auto-pilot! So even though an engineer, he baby sat the auto-pilot while the others were below.

### NOTICES TO TAKE NOTICE OF...

This month is THE A-7 "Anyway You Want" want contest. Remember to finish and bring your quality and/or creative A-7 to this contest. In fact, bring any A-7 model you built anytime.

We still need donations for the Club Auction in July, so if you can bring them in to this meeting so we can get them prepped for the auction.

Remember to bring any new interesting books, mail-order purchases, recently (or otherwise) finished models, for the Show & Tell.

Remember, if you checked out video tapes, PLEASE RETURN THEM at THIS meeting.

I believe we will have a demo at this meeting, but I have lost track of whether this was supposed to be Rodney's "How to Spray SNJ Metal Paints".

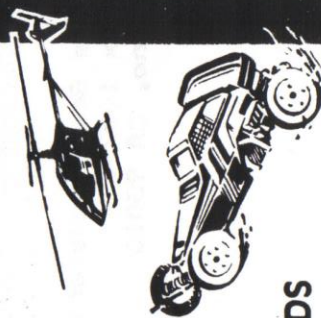

2ND ANNUAL NORTHERN CALIFORNIA

MODEL & HOBBY

EXPO

JUNE 17-18-19, 1988

SANTA CLARA COUNTY FAIRGROUNDS

344 Tully Road • San Jose, California

SEE THE LATEST PRODUCTS AND TALK WITH MAJOR MANUFACTURERS AND DISTRIBUTORS OF RADIO CONTROLLED MODEL AIRCRAFT, BOATS, CARS, TRAINS, PLASTIC MODELS, GAMES AND MODELING ACCESSORIES!

OUTDOOR EVENTS: Helicopters, gliders, aircraft flying demo's at the ongrounds flying site. R/C CAR ACTION - Demo's 1/4 scale cars and dragsters 1/12 & 1/10 cars.

TRADE ONLY: FRIDAY, JUNE 17 - 10:00 AM to 4:00 PM

GENERAL PUBLIC: FRIDAY, JUNE 17 - 4:00 PM to 9:00 PM

SATURDAY, JUNE 18 - 10:00 AM to 5:00 PM

SUNDAY, JUNE 19 - 10:00 AM to 5:00 PM

Also there are Static Display Competition, Train Displays, Boat Pond, Flying Site, Car Track and Door Prizes.

ADMISSION: Adults - \$5.00, Under 12 - \$3.00  
Under 6 - FREE with Adult.

TO EXHIBIT: call Show Office (408) 296-5511 or (408) 296-8580.  
467 Saratoga Avenue, Suite 110, San Jose, CA 95129

Northern California  
MODEL AND HOBBY EXPO is  
the #1 show in Northern Calif.  
**THE SHOW YOU  
CAN'T AFFORD  
TO MISS!**



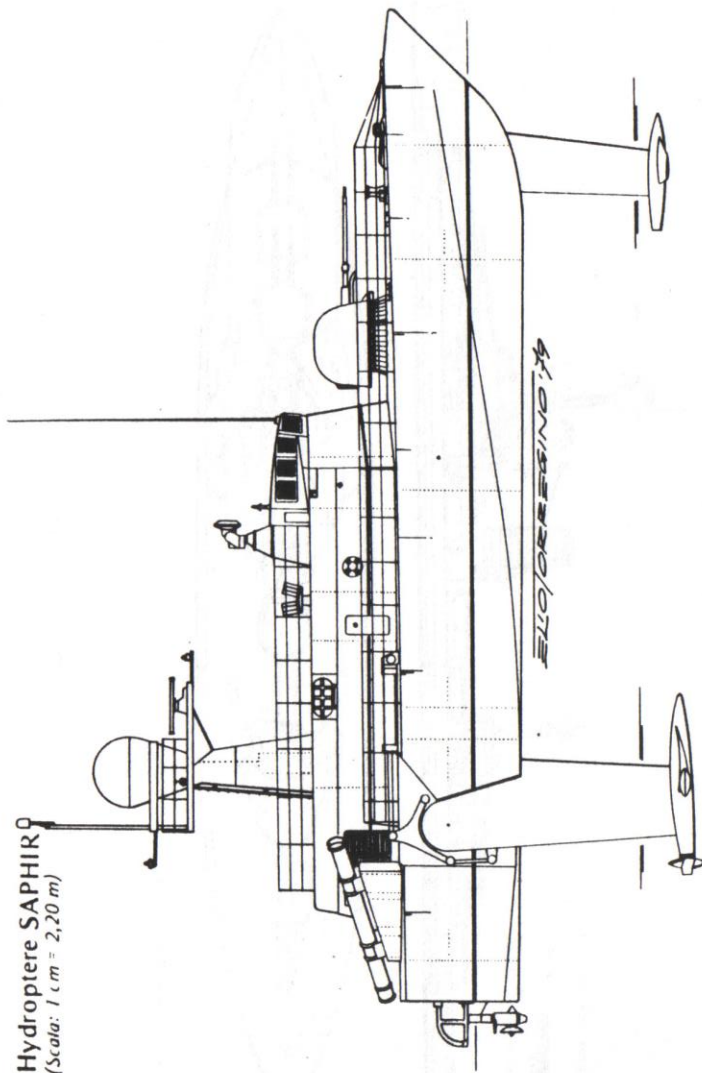

## COMING ATTRACTIONS

- SWAP & AUCTION:** July 16, San Jose Scale Modelers at Mercury Savings Sept. 5, WMCA Model Car Swap, Castro Valley Community Ctr.
- CONTESTS:** Aug. 3-10, IPMS/Nationals, Dayton, Ohio
- DISPLAYS:** June 17-19, Santa Clara County Fairgrounds; Model & Hobby Expo. Admission \$5.00, under 12 \$3.00
- July 23, Sacramento Model Car Show '88 - 12-7 PM, Special Theme; Pony Cars 1964-1974. Rodeway Inn, Watt Ave. at I-80. Admission \$3.00 Contact: David Tucker, 6242 Cardigan Ct., Citrus Heights, CA 95621
- August 20, GoodGuy's West Coast Nationals '88/Street Rods. Model Car Show in Conjunction. 10-4:30 PM. Pleasanton, CA (Alameda County Fairgrounds). Contact: Eyeball Engr., 605 Debbie Dr., Santa Rosa, CA 95407
- October 2, Model Car Show, in conjunction with Modesto Concours D'Elegance. All model cars welcome, special theme: Lincoln Continentals. Contact Vince Nemanic 209/522-4729 or Bobby Duvall, 209/577-4769 or write P.O. Box 2327, Modesto, CA 95351

### AIR SHOW TEAMS:

Blue Angels - 8/20-21; NAS Miramar, 10/8-9; NAS Point Mugu  
 Thunderbirds - 6/18; Mather AFB, 7/2; Redding, CA, 7/3-4; Moffet  
 NAS, 8/10; Beale AFB, 9/17; Reno (Air Races), 9/18; Vandenberg AFB,  
 10/29; Salinas, 10/30; George AFB, 11/12; Bakersfield

### AIRSHOWS:

June 25-26; Truckee-Tahoe Air Show - 10-4pm. Waco Wing Walkers, Don Beck race demo, Parachuting (US Army Golden Knights & the all-female Chuting Stars), Sailplane act, Balloon Race. Antique, Experimental & Warbird display & flyby's. Truckee-Tahoe Airport, Hwy 267, 916/587-4119.

### AUTO RACING: Sears Point International Raceway - 707/938-8448

June 25-26; NHRA Winston Drag Races  
 July 1-3; Shelby American Convention  
 July 29-31; NHRA Motocraft-Ford California Nationals,  
 Aug. 12-14; 13th Annual L-M California GP/INSA Camel GT  
 Sept. 16-18; Super Chevy Sunday Weekend  
 Sept. 23-25; General Tire SCCA Championship  
 Oct. 8-9; CSRG Vintage Car Races

**Palo Alto Concours D'Elegance;** June 26 - Next to Stanford Stadium, El Camino Real & Embarcadero. Contact Don Day, 408/446-0689

For registration to attend the National Shelby American Convention, write to SAAC 13, c/o Don Odiorne, 1054 Sherman Dr., Salinas, CA 993907. Here is a quick schedule of what it going on:

- June 30/Thursday - Sears Point Raceway: Bondurant School special half-day course. Evening (5:30) Drag Racing, Grudge & Bracket.
- July 1/Friday - Sears Point Raceway: 9-5 Open Track. El Rancho Conv. Ctr./ Santa Rosa: 8-? Tech Questions
- July 2/Saturday - Sears Point Raceway: 9-5 Open Track. El Rancho Conv.Ctr./ Santa Rosa: 7:30-Cocktails, 8:30-Guest Speakers
- July 3/Sunday - Luther Burbank Center for the Arts/Santa Rosa: Car Show 8-6

Chile

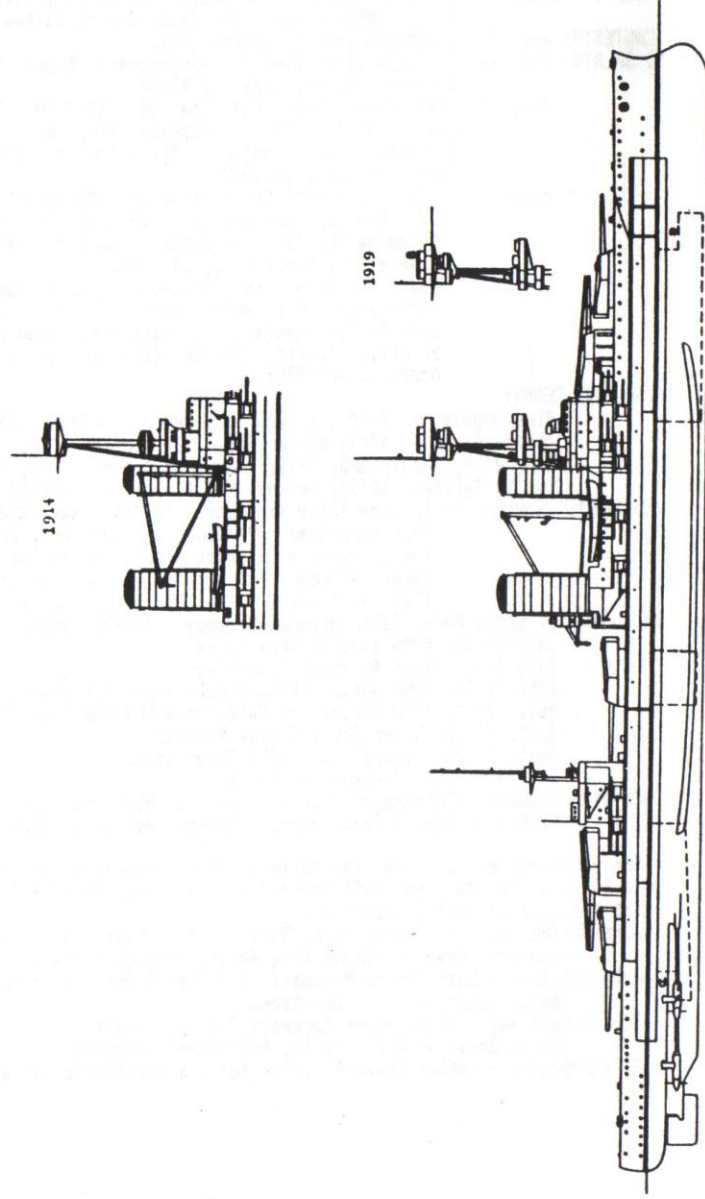

Almirante Latorre : Canada (1916) (Aircraft take-off platforms on B and D turrets only from 1918 onwards)

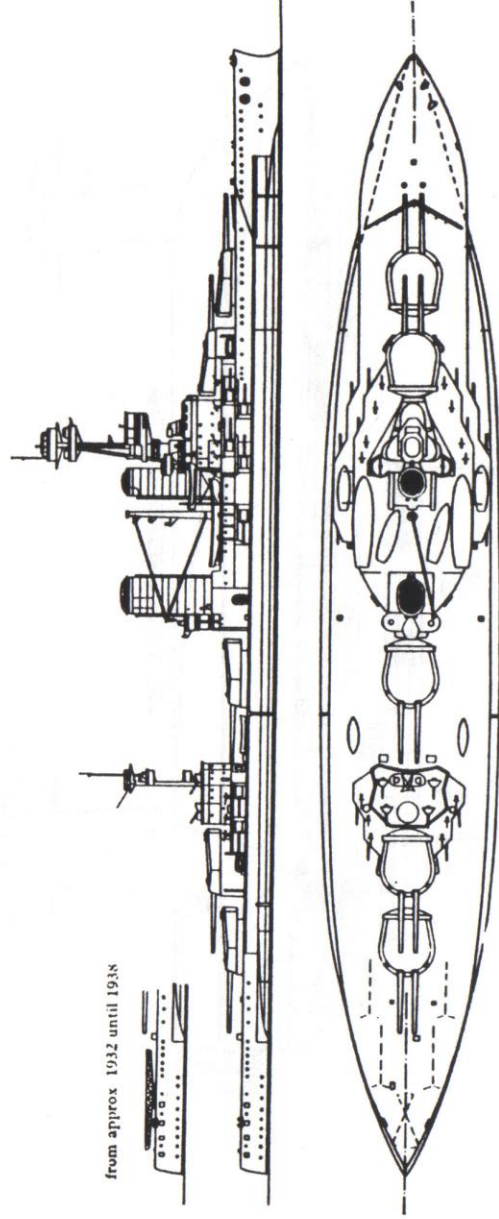

Almirante Latorre (1935)



BUILDING THE CHILEAN BATTLESHIP ALMIRANTE  
LATTORE IN 1/700 SCALE

HISTORY

In the early 1900's the Chilean government purchased two new dreadnoughts from the ship-building firm of Armstrong in Great Britain. The Chilean government felt that if they were to protect the borders and coast from aggression from other nations that they had to join in on South America's own naval arms race. Chile's main rivals were Argentina and Brazil. In November of 1911 a ship's keel was laid down bearing the name Of Chile's main seaport city, Valparaiso. The ship's name was later changed to Almirante Lattore. Her namesake was a captain of a Chilean ironclad in the War of the Pacific (1879).

A month before the ship was to be completed, World War I had begun. Britain saw a need for more fighting ships and decided to seize the nearly finished ship and purchase her for the Royal Navy. In September 1914 the newly commissioned H.M.S. Canada joined the British Grand Fleet. In 1916 Canada was part of the battleline that faced the German High Seas Fleet when the two fleets clashed at Jutland. She served the war without damage and continued in British service until re-purchased by Chile in April, 1920.

The ship was again named Almirante Lattore. Chile could now protect her maritime rights and serve notice to other countries that she now had the means to do it. The ship now served to show Chile's flag at various South American ports. By summer of 1928 Almirante Lattore was ready for a major refit and entered Devonport, Great Britain to be rebuilt.

When finished, a host of new improvements had been added. New torpedo bulges, new machinery, and new bridgework were among the modifications. Also at this time new turbines and oil burning boilers were installed. By early 1931, when completed, the ship was as modern as any other country's battleship. Just after Pearl Harbor, the United States approached Chile with an offer to buy Almirante Lattore. The U.S. considered to buy her because of the losses to the battleline at Pearl Harbor. Chile declined because they felt their needs were more important. Almirante Lattore served her country for the next three decades as a quiet and peaceful deterrent to the Great South American arms race.

CONSTRUCTION

I always find enough reference pictures before I begin a project. Some good information and pictures can be found in various issues of Jane's All the World's Ships. Seigfreidd Breyer's Battleships and Battlecruisers was a must for the plans I was going to use to make the model. These plans are in 1/1250 scale and they would have to be enlarged to 1/700 scale.

I began with the main source of parts, Airfix's Iron Duke kit. I glued the two hull halves together, and after drying, I cut about 1½ inches out of the midships section. I then glued the two new halves together, ending up with a hull of 10½ inches at the waterline. I then made new decks using Evergreen



brand plastic sheet which has been prescribed for H.O. scale passenger car siding ( $2\frac{1}{4}$ " spacing, thickness of .030). The foredeck was a new shape compared to Airfix's Iron Duke bow so a little putty shaping was necessary later. It was also necessary to putty over the casemate guns on the stern. Various deck levels were made of plastic sheet and strips, glued together, puttied, sanded, and then painted. The main bridge was modified from Hasegawa's Hyuga kit with many new decks added. Various parts from the Iron Duke were used for the bridge as well as scratch built deck levels. The fighting top was a much modified part from the Airfix kit.

The two stacks were also from the Airfix kit. The aft stack was widened about 1/8" with plastic strip and then puttied and sanded to shape. The ship's launches were from the spare box and the launch derrick was a cut down part from the Iron Duke kit.

The after superstructure was again built up from sheet plastic and plastic strip. The mainmast assembly was made up of 11 pieces carefully assembled one piece at a time, with time for drying of the glue. The spare box supplied all the correct shapes.

All of the deck hatch covers were made from strip plastic painted dark gray and glued to the correct places. The four main deck vents were modified parts from the Matchbox U.S.S. San Diego kit. The paravanes were from Italaerei's Deutschland kit. All of the A.A. guns were from that kit, also. Finally we came to the main 14" battery which were slightly modified from the Hasegawa Hayuga kit.

As a final touch I made the national flag and jack of Chile. I started with Microscale solid color decal sheets, one red, one white, and one blue. I cut a white field large enough for the national flag and cut the red and blue fields to fit. After applying them and letting them dry, I painted on Tamaya's acrylic clear and formed the flag while it dried. The white star was added later, and also painted over clear. The jack flag was much easier, as it was only a blue field.

I chose to paint Almirante Latorre in the colors of an ex-Navy warship of the 1920's. The teak deck was painted Tamaya's acrylic color deck tan XF-55. All the vertical sides were painted dark sea gray XF-54. Other decjs were painted with Tamaya's dark gray ZF-24. When finished the model represents Almirante Latorre fresh from her 1929 refit in England. As a final step I laid the model in an ocean of blue tinted acrylic gel. After it was dry I worked up the ship's wake pattern with white tinted gel medium. I spent a lot of time painting the wake until it was shaped just right. when it was finished I had a 1/700 scale example of Chile's contribution to the great South American naval race.

Jane's All the World's Ships issues 1931, 1950, and 1957-

The World's Warships -R.V.B. Blackman-Hanover House

The Complete Encyclopedia of Battleships Tony Gibbons-Crescent Books

Battleships and Battlecruisers Seigfried Breyer



# IMAGINE . . . masking and painting over realistic natural metal finishes!



## SnJ model products

Introduces  
**SPRAY METAL**  
A Natural Metal finishing system



SnJ Model Products Spray Metal is an enamel-based paint that dries to a hard and permanent surface; not an always soft and waxy surface. The hard surface of Spray Metal resists fingerprints and is safe to handle during completion of the model.

### A few of the benefits of using Spray Metal are:

- Spray Metal is easy to apply.
- Spray Metal can be masked over with your favorite masking materials.
- Spray Metal can be polished to a very high shine by using the Polishing Powder. The polished areas are safe to mask over.
- All metal areas can be completed before adding anti-glare panels or stripes.
- Surface detail can be enhanced by brushing black India Ink on the areas to be enhanced. Allow the ink to dry and then remove the excess with rubbing alcohol on a soft cloth.
- Spray Metal can be tinted with gloss enamel paints to simulate other metals.
  - Steel:** 3 drops black, 1 drop dark blue, add to ½ oz. Spray Metal Aluminum.
  - Titanium:** 2 drops black, 2 drops dark brown, 1 drop orange, add to ½ oz. Spray Metal Aluminum.
- Differences in Aluminum panels are easy to accomplish by tinting the Aluminum paint or by buffing with or without the polishing powder.

SNJ SPRAY METAL is a new metal paint with a different twist — spray-on paint and rub-on silver powder. SnJ's starter kit includes a 1½-ounce bottle of silver paint, ½-ounce bottle of silver powder, ½-ounce mixing bottle, black buffing cloth, and detailed instructions. SnJ says its product can be masked without lifting and can produce three shades of silver with one application.

As with any method of producing a bare-metal surface, the plastic must be completely smooth and blemish free. The silver paint must be airbrushed and SnJ suggests waiting 5 to 10 minutes between each of three misted coats. After the silver paint has dried for at least an hour, selected panels can be buffed to a metallic sheen. The silver powder can be polished onto panels to produce a shinier surface and should be applied within 12 hours of the silver paint. After 12 hours, all the surfaces can be masked.

The paint sprayed on easily and resulted in a pleasing semigloss aluminum finish. Buffing increased the gloss, but produced a silver-speckled effect. Buffing the silver powder over this, though, results in a much better metal effect. Additional applications of the powder and polishing make the panels even shinier.

I applied masking tape and Scotch Magic tape over unbuffed, buffed, and silver polished panels. After leaving the tapes on the model for 30 minutes, when removed both lifted a few silver flecks but didn't mar the surface. The areas polished with the silver powder were more susceptible to fingerprints, but the prints can be polished out with a soft rag. SnJ Spray Metal can be toned by adding enamels, but I didn't try this.

My first try with SnJ Spray Metal produced good results, and I hope further practice will reveal its full potential.

Paul Boyer  
FSM



## SnJ model products

P.O. Box 608  
Carmichael, CA 95609

From the July/August 1985 *FineScale Modeler* magazine reproduced with permission.



## INSTRUCTIONS

(Please read carefully before using product)

IF USED PROPERLY, MASKING TAPE WILL NOT MAR THE FINISH OF SnJ SPRAY METAL

### A. Preparing the Model

1. The plastic must be free from all blemishes and imperfections.
2. No primer is needed with this product.



Color cups are not recommended for use with Spray Metal.

### B. Applying SnJ Spray Metal

1. Mist 3 or 4 coats of SnJ Spray Metal onto the areas to be painted.
2. Wait 10-15 minutes between each coat. This will result in a semi-gloss aluminum finish. (Applying the paint "too wet" will result in a glazed or wet appearance on the model.)
3. Simply paint one section at a time on large models. After 1 hour a section can be safely handled to aid in painting other areas.

### C. Buffing the Finish

1. After the model has been completely painted and has set for at least 1 hour the finish is safe to handle and mask over.
2. Mask over any panels you wish to retain semi-gloss.
3. Using the polishing cloth provided, buff the remaining surfaces. By regulating the amount of buffing to the paint you can achieve different tones on panels. This can be done by buffing some panels and masking over them and then buffing other panels more.
4. To achieve the highest shine use the Polishing Powder. The more times you buff an area with powder the shinier that area will become. For this reason you should work on only one or two panels at a time. Again, by buffing some panels more than others you can achieve several different tones.
5. Let the model cure for at least 12 hours before continuing.
6. After the 12 hours, it is safe to proceed with masking and any additional painting, either spray or hand, over the SnJ Spray Metal.

### D. Different Tones

If you wish to have different colors of panels, alter the SnJ Spray Metal with gloss enamel paints. We recommend Testor's Pla-Colors. If you use the powder to buff these panels, the powder will not change the color substantially.

### E. Sealing the Finish

NO SEALER IS REQUIRED OR RECOMMENDED.

### F. Decals

Apply decals as you normally would. No clear gloss is needed as the finish is extremely smooth. None of the popular setting solutions or softening solutions had any apparent effect on the finish. To flat your decals (if desired) use any of the popular flats and either spray, with airbrush set on very fine, or hand brush with thinned flat.

### G. Fingerprints

SIMPLY BUFF THEM AWAY WITH A CLEAN CLOTH.

**IMPORTANT NOTE:** SnJ Model Products recommends that you wear a protective mask while using the Polishing Powder to ensure against inhaling the dust.

If you feel this product is defective, return the used portion to us for replacement. Since the manufacturer has no control over this product's use, we assume no liability for improper use.



P.O. BOX 608 CARMICHAEL, CA 95609



# Meikraft Models Presents

Injected Molded State of the Art Short Run 1/72 Scale Kits

First Release 1/72 Scale  
Sugar-Baker-Two-Uncle  
Voight SB-2-U Vindicator

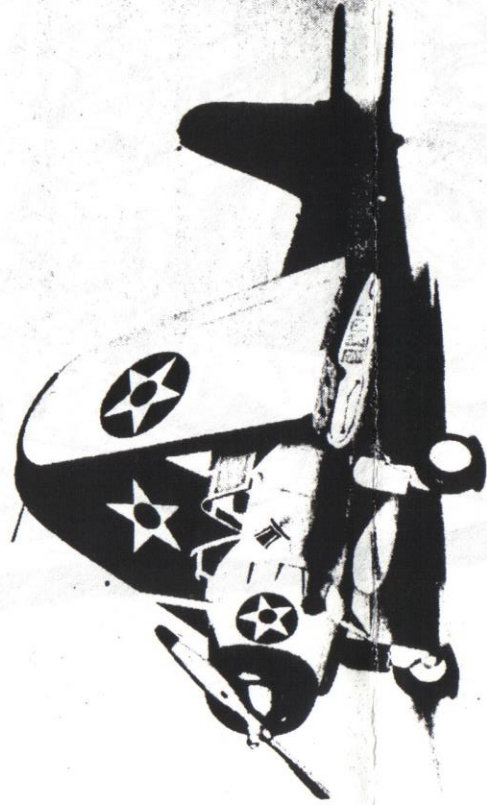

## 2 Versions

Parts to build either version

- Wings Up or Down
- Cowling Open or Closed
- Canopy Open or Closed
- Bomb or Fuel Tank
- Decals - American, French, British (No Roundels)
- Brass Etch Detail Parts
- Free First 2000 Kits - A \$2.95 Value
- 52 Injected Molded Parts
- Extensive Instructions

## A Fitting First Release

Send \$1.00 for 4 page Meikraft catalogue and reserve your Vindicator NOW!

A selection of options that should please any modeler.

Vindicator Sent Insured	\$11.95
Postage & Handling	<u>2.00</u>
	\$13.95

## Next Releases

- Aeronca Glide Bombs
- WW1 Wheel Halfs, 1/72 and 1/48 With & Without Brass Centers
- P35 & P35-A Same Features
- H.B. W-29 Float Plane
- Piper Cub

Release date of Vindicator - June 15, 1988  
Others to follow very soon

Distributed By  
AVIATION USK  
602 FRONT ST. BOX 97  
USK, WA 99180



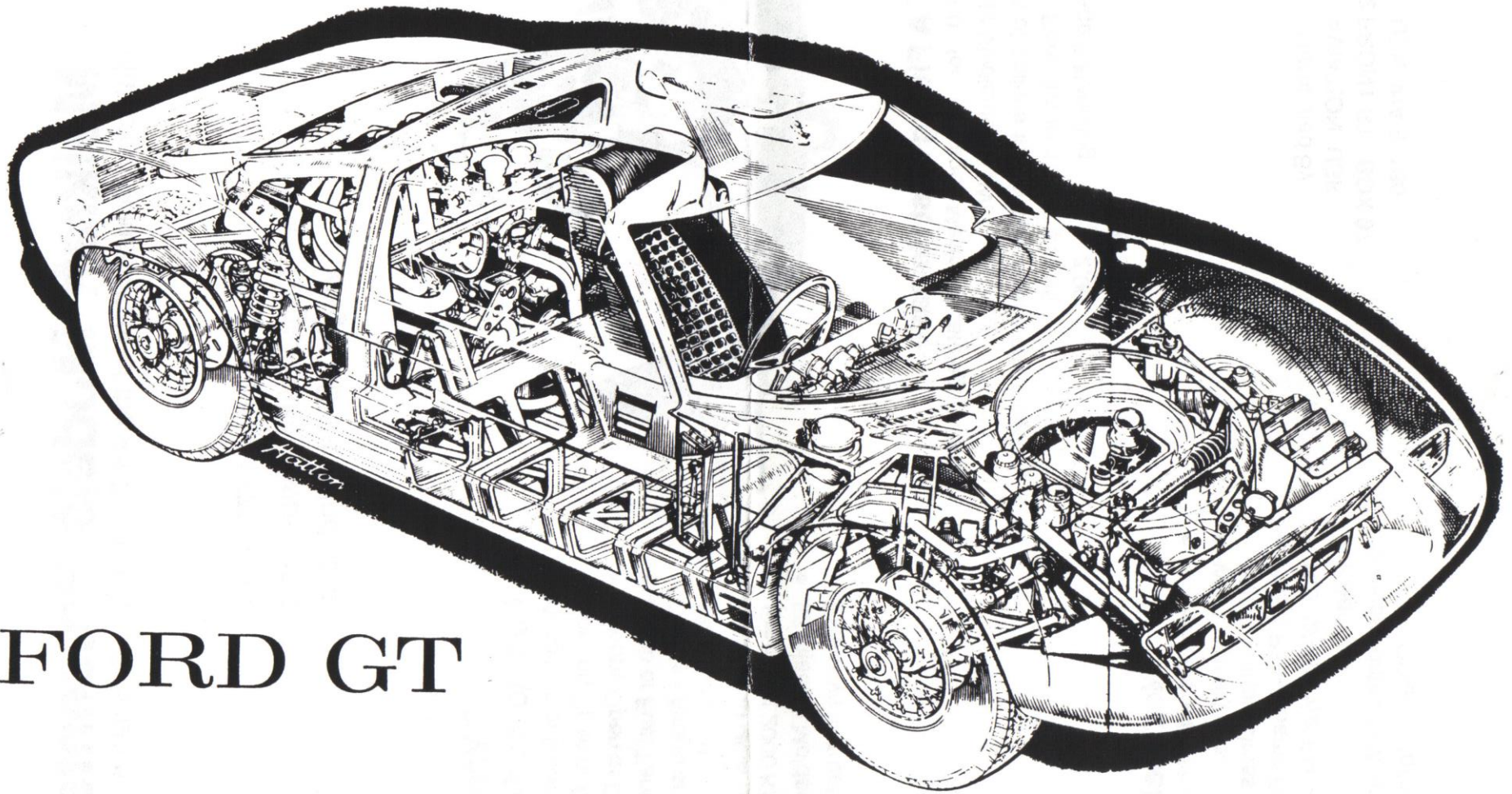

FORD GT