

BOOK COLLECTION FOR SALE THIS MEETING

80+ Books, priced to sell and in excellent condition. Example: The Epic Of Flight Series by Time-Life Books, a \$350+ value for just \$100 (23 volumes)! Other Titles: The Great Air Races, History of Aviation, Flying Fortress, German Combat Planes, Luftwaffe-a Pictorial History, Mustang, Spitfire at War, Airwar Vietnam, Soviet Air Power, and the list goes on. NO ONE BOOK OVER \$10.

San Jose Scale Modelers
P.O. Box 1052
Cupertino, CA 95015

IMPORTANT: Check the Year/Month code following your name for your dues expiration.

DAN BUNTON
910 NIDO DRIVE
CAMPBELL CA 12345

FIRST CLASS MAIL



SAN JOSE SCALE MODELERS

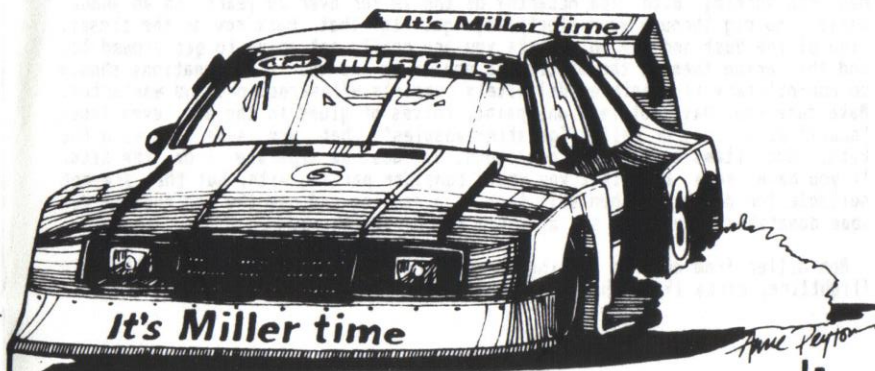

IPMS-SAN JOSE

OCTOBER 1987

Next Meeting: 7:30 PM Yak & Book-Buy
8:00 PM Bus. Formalities
8:40 PM In the Water, w/Bert

Location: Mercury Savings Meeting Room
19376 Stevens Creek Blvd.
Cupertino

MINUTES FROM SEPTEMBER MEETING

Brevity was the order of the evening as we made quick work of the business issues and moved quickly to the social hour. Eric McClure announced he had not had anyone sign the Beginner's Classes sheets at D&J and San Antonio Hobby shops. One of the other members said he had several young modelers interested so it is possible that we will have a class soon. We will see what Eric has come up with since the October meeting. If there now is enough interest, we can go ahead, otherwise the idea will be shelved until there can be determined that there is enough interest to justify having a class, as well as enough time and energy within the club to instruct it.

Barry Bauer, our V.P. (for Versatile Performer), took more volunteers for the February '88 Annual Contest Committee. Also, our next Quarterly Contest will be in December...though no theme was thought of.

CAMEL GT

Bill Magnie spoke on our annual cooperation with the Veterans Administration Hospital in providing them with kits for the rehabilitation of patients. Bill has been working with Tom McCarthy of the VA for over 20 years, on an annual basis. So dig through your stockpile, get to that back row of the closet, blow of the dust and see which kits you are really not going to get around to, and then bring them to the meeting to donate to the VA. Kit donations should be non-military if possible, definitely complete w/instructions and unstarted. Make sure you have not left any paint, knives or glues in the box, even those "scale" glue tubes or Heller "gelatin-capsules" that are supplied with the kits. Such items are welcome donations, but must be separate from the kits. If you have some kits that you would consider parting with, but they are not suitable for donation, then sell them at a meeting and use the proceeds to buy some donatable sale kits, say at K-Bee toy or something.

Bob Miller from NASA is looking for someone interested in modeling the NASA flightline, circa 1946. He can be reached at 252-7842.

NEWER NEWS

This month's HOW-TO discussion is by the Admiral himself, on how he creates those miniature oceans for his 1/700 scale ships that look so real they have you watching for JAWS before you get too close. Bert said the technique is easily adaptable for any scale and will have an actual demonstration at the meeting, not just an explanation.

On our letter to the IPMS/USA, I have, as yet, received no response from any official as to whether they plan to respond directly, publish their response, not respond, or even that they confirm receiving our letter. This is as of October 10, 1987. If I have no response by the meeting, I will send a follow up to them to hopefully confirm their intentions. I have received other very reliable information since our last meeting that confirms some of my suspicions...these being that much of the problems that are so worrisome come from the Rob Wolfe administration and their lack of thorough records. It has made it very difficult and lengthy time-wise for Fred Hall's group to get things back on track, but they are earnestly and openly trying. Now if we can just get Fred to write it up that way, in a complete form.

Additional IPMS/USA info; I do not know how many of our national members have received this information, but it made its way into the PLASTIC ATTACK of the IPMS TRAVIS. Contained in their newsletter was an actual copy of a letter from Fred Hall to "Member IPMS/USA". I quote, "We'd also like to introduce a new "newsletter" type publication soon to be available. In it will be found most of the non-modeling related letters and politics that occur within any Society of our size. You can receive this newsletter only by separate subscription of \$5, and if this aspect of IPMS does not appeal to you, you will neither have to tolerate it in your magazines, nor subsidize its cost." I have commented previously on my feelings about this separate, additional cost information, so I will not repeat it here. This information was contained in a letter that was primarily a renewal promotion letter. In it was also said that they "fully expect to print the full set of six Updates and four Quarterlies...we are open to your ideas and suggestions....feel free to call (Fred Hall) in the evenings at (402)421-1643."

Despite my lengthy constructive criticisms of recent, I still strongly encourage you to join, or renew with IPMS/USA. It is a valuable agency for modeling as our hobby and a viable industry. Membership is \$24 a year (plus that \$5.00 if you want the Political News). Write to IPMS/USA, PO Box 6369, Lincoln, NE 68506. Membership year is from July to June. You can not voice your opinions to them if you are not a member, and simply not renewing or ever joining will not be recognized as a critical comment.

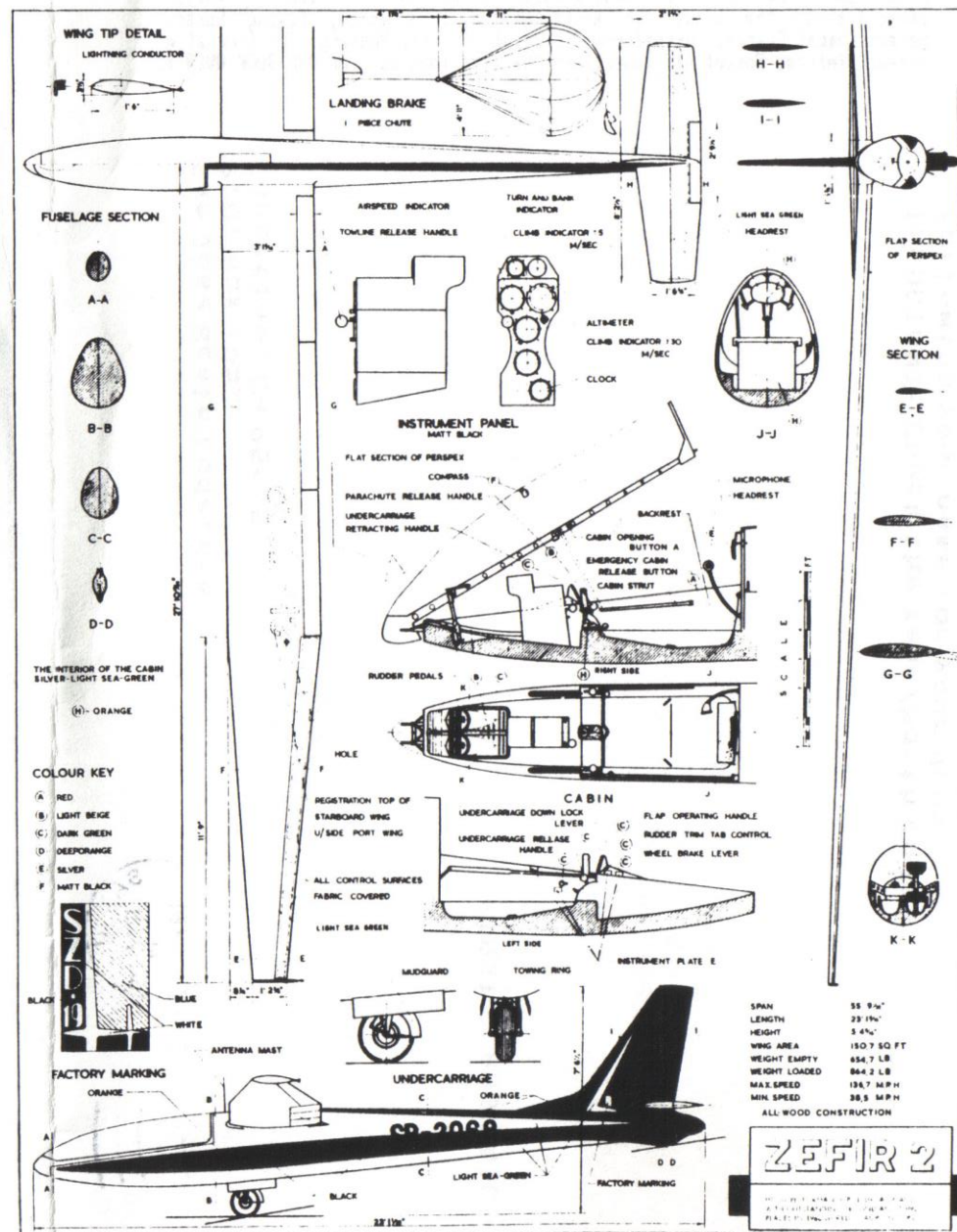

3-LITRE LOTUS-BRM (1966)

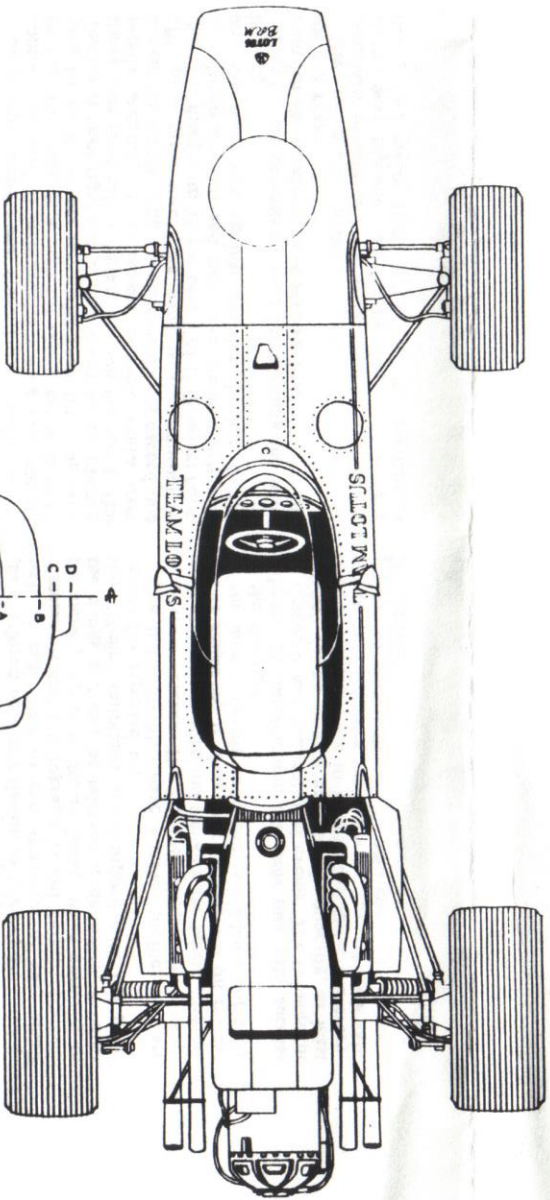
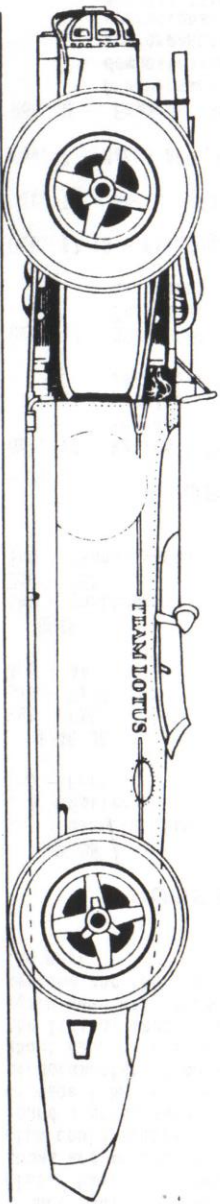
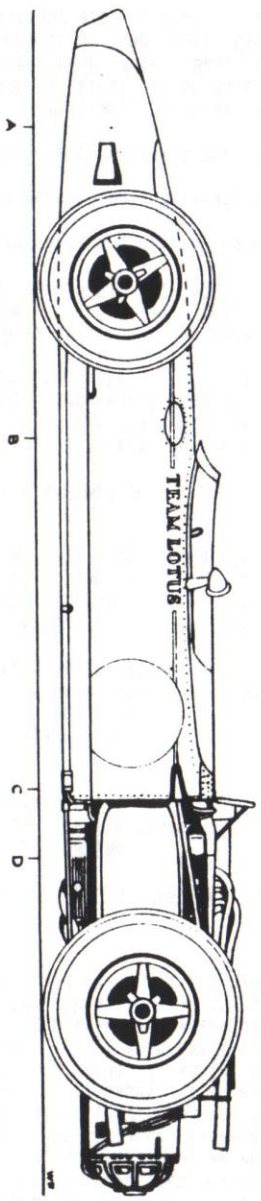

1/24 SCALE

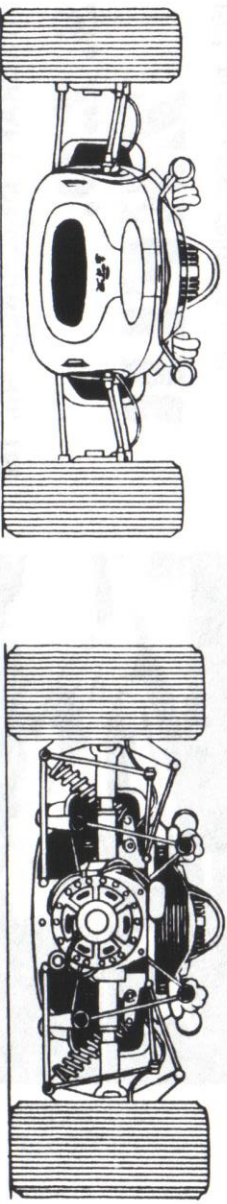
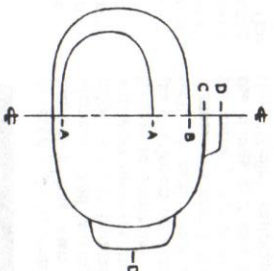

AIRCRAFT DESCRIBED No. 162

S. Z. D. ZEFIR

High performance Polish Sailplane
Drawn by F. Pawlowicz

DESIGNED by a team under the guidance of Bogumil Szuba the Zefir sailplane has been built in fair numbers by the "Szybowcowy Zaklad Doswiadczalny" (Sailplane Experimental Centre) and is also known under the designation "SZD-19-2".

Since the "Zefir" was created as a sailplane for competition work it incorporates a wing with laminar profile. This ensures a high lift coefficient with small drag losses. Wide spar strips also form the wing skin, making it very rigid and exceptionally strong (during static tests steel cables broke, but not the spar). The profile accuracy is to closest possible limits over almost the whole wing—deviations do not exceed one fifth of a millimetre! The wing is also unusual in that it is fitted with 35 per cent VZLU (Fowler) flaps, non-slotted ailerons and small end plates which protect the wing tips against possible damage during landing.

Plastics are extensively used for building the wing both for the sandwich nose section, flaps, and for the trailing edges.

Use of plastic material—polyester laminate—is especially evident in the fuselage. Since this material allows easy reproduction of any shape, and is very strong—the entire front section of the fuselage is



covered with it, both on the outside and on the inside. Laminate has also been used for all streamlined elements, and fairings. The reclining position of the pilot reduces frontal area to an absolute minimum and also involves unusual controls (the prototype had hydraulic controls). High quality Polish instruments (as employed on many British sailplanes) are fitted as well as radio and oxygen apparatus of very small dimensions and a barograph. A tail parachute serves the same purpose as the air brakes fitted normally in the wings and can be released if necessary. Production "Zefir" sailplanes are equipped with tail parachutes for repeated use.

The tail units also have laminar profiles and are wooden structures. The fin and tailplane have sandwich skin, the rudder and elevator are fabric covered. The single leg landing gear is retracted on release of the launch towing rope and is hidden completely in the fuselage.

From its introduction, the Zefir met with success in domestic and International events. The subsequent "Foka" design is now exported in quantity, at least one is in regular use in Britain and modellers everywhere have followed the inspiring lines of these sailplanes for slope-soaring and who could blame them for copying?

Once again, I would like to promote the idea of the video library for the club. Many of us have VCRs and have recorded many interesting documentaries, shows and movies that we could share, and many that we would like to get. The club could supply the blank tapes. For instance, in my Beta format, I just found a great sale on Kodak L-750s at only \$2.00 each! That is about 45 hours of tape time for the \$21+ I spent on 10 tapes. I already have over 35 hours of documentaries on military and space that I would be glad to copy. How about each of you take a few minutes to jot down the titles you have and bring the list of them to the meeting. Then we will try and discuss the idea, which again was that someone would be the librarian, and bring the tapes to the meeting and then any club MEMBER could check out one tape from one meeting to the next.

QUARTERLY CONTEST RESULTS

JUNIOR ?	JUNIOR CAR	JUNIOR ? A/C
1st - Hannover Bipe	1/12 Lola T70 Mk3B	Fiat 655
2nd - Fokker D23	Ferrari	
3rd - Feisler		
1/48 JET	1/48 PROP	1/72 JET
1st - F5E	1st - Do335 A/2	1st - T-33/TV-2
2nd - F105	2nd - Ki44 Oscar	2nd - A10
3rd - A4	3rd - Macchi 200	3rd - Saab Viggen
SHIP	MISC.	SPECIAL - CAMOUFLAGE
1st - Yorktown	1st - Viking	1st - LST
2nd - LST	2nd - Tiger II	2nd - FS/Fighter School
3rd - Pennsylvania	3rd - Alien Spaceship	3rd - Saab Viggen

UPCOMING EVENTS

- Oct. 17 - Region 9 Contest #2, Farmer's Market, Tulare & U St. (next to Rt.41) Fresno. Registration from 9AM-1PM, \$2 per entrant (waived with proof of current IPMS/USA membership) and \$1 per model. Swap table available by pre-registration until 10/1/87; \$10/1 or \$15/2.
- Oct. 17 - MODELRAMA - Swap Meet/Display/Contest for model cars. Sponsored by Sacramento Auto Modelers. Rodeway Inn, I-80 at Watt Ave., Sacramento. Info: Pat Farrand 916/331-3626.
- Oct. 17-18 - Pt. Mugu NAS Air Show, Oxnard - Military display & open house.
- Oct. 25 - Norton AFB Airshow, San Bernardino - Military display & open house.
- Nov. 7 - March AFB, Riverside - Military display & open house.
- Nov. 8 - Edwards AFB, Mojave - Military display & open house: 40th Anniversary of the USAF & first supersonic flight. Supersonic demonstration by retired USAF Brig. Gen. Chuck Yeager. Aerial performances by the Thunderbirds and Test Center A/C. Displays of operational, test and antique a/c. Contact: Public Affairs Office - 805/277-3510
- Dec. 5 - Silver Wings Contest - Sacramento area IPMS
- Aug. 3-7, 1988 - IPMS National Convention/Contest-Dayton, Ohio

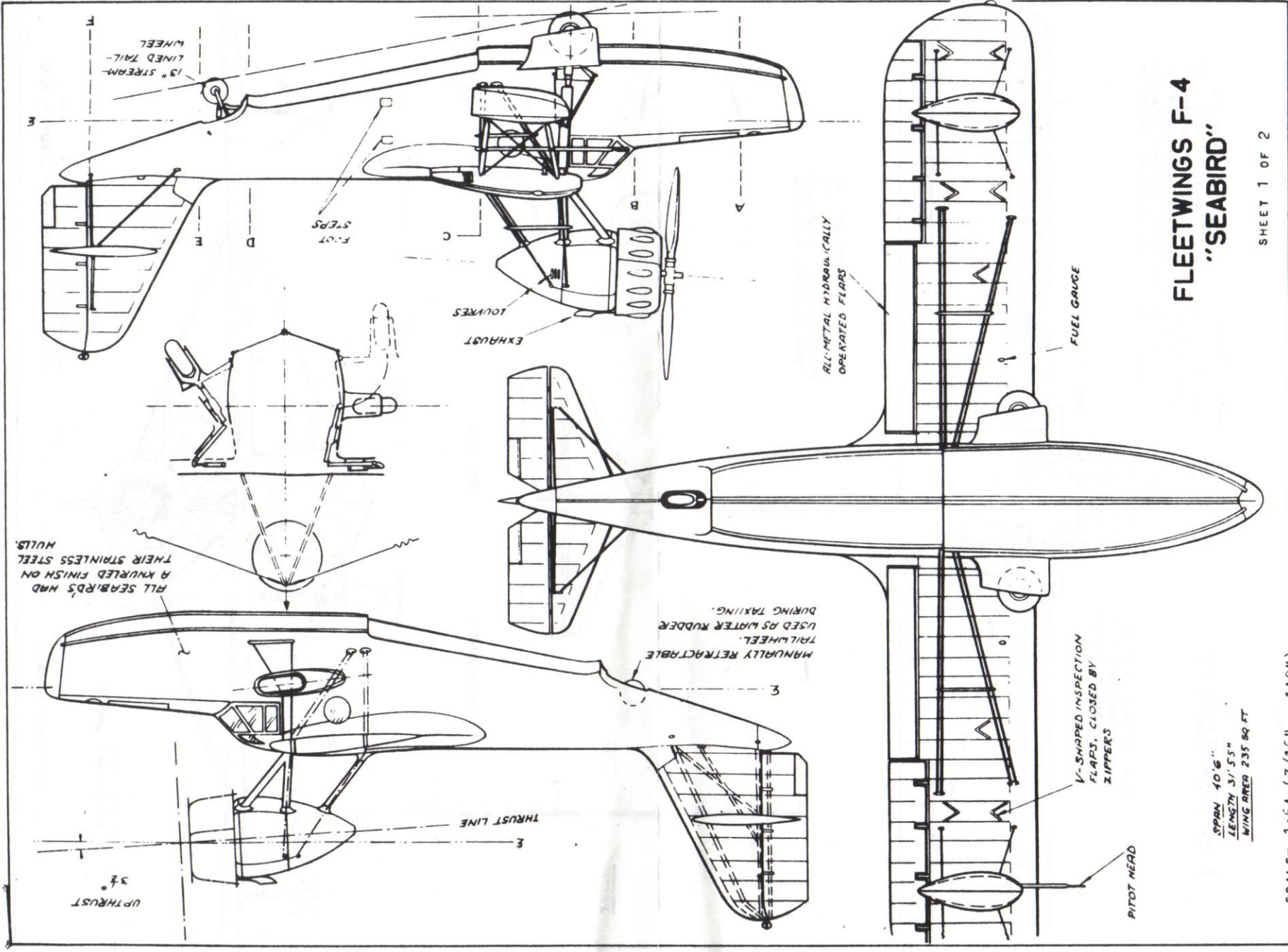

FLEETWINGS F-4 "SEABIRD"

SPAN 40'6"
 LENGTH 31'5.5"
 WING AREA 235 SQ FT

FLEETWINGS F-4 SERIES: 285-HP JACOBS
— " — F-5 — " — : 300-HP JACOBS

ENGINE: JACOBS L-5,
285-HP AT 2000 RPM

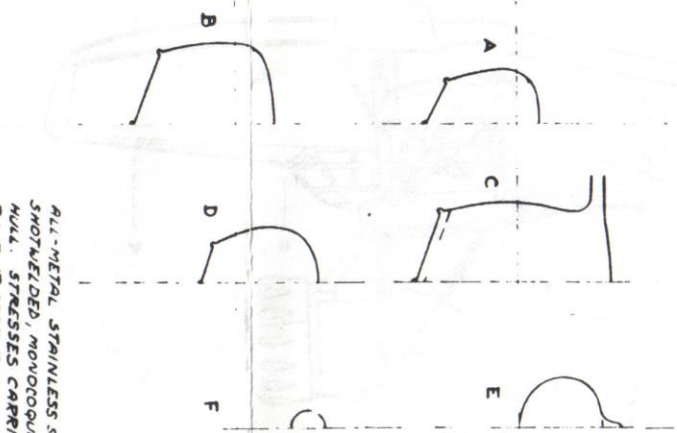
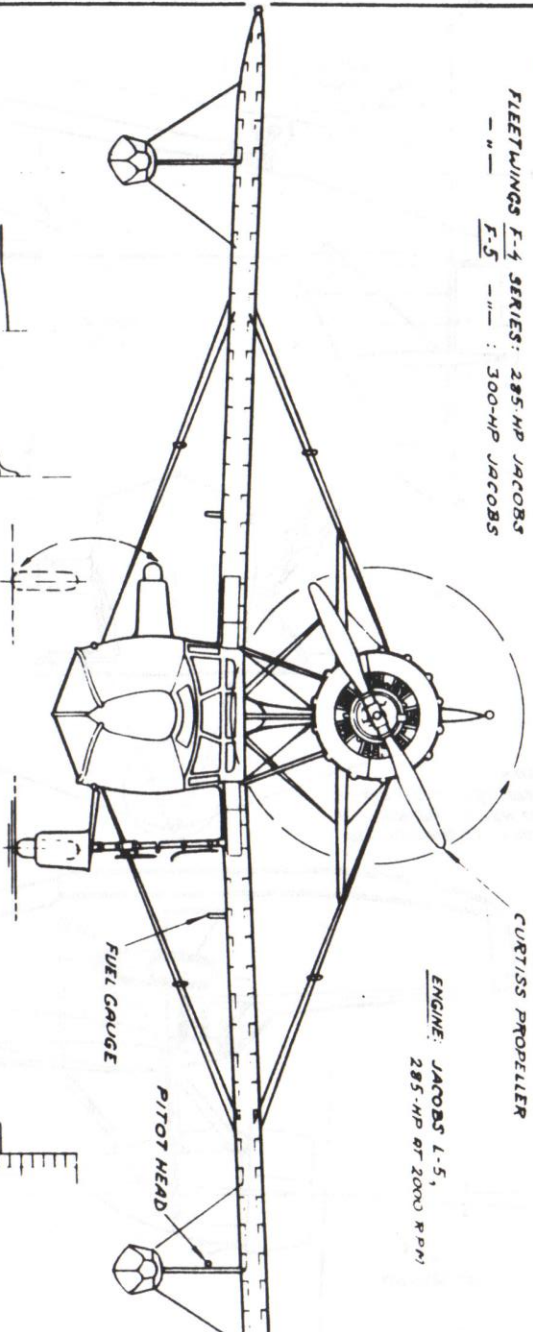

ALL-METAL, STAINLESS STEEL,
SHOTWELDED, MONOCOQUE TYPE
HULL. STRESSES CARRIED BY
BUILT-UP STEEL TUBES.

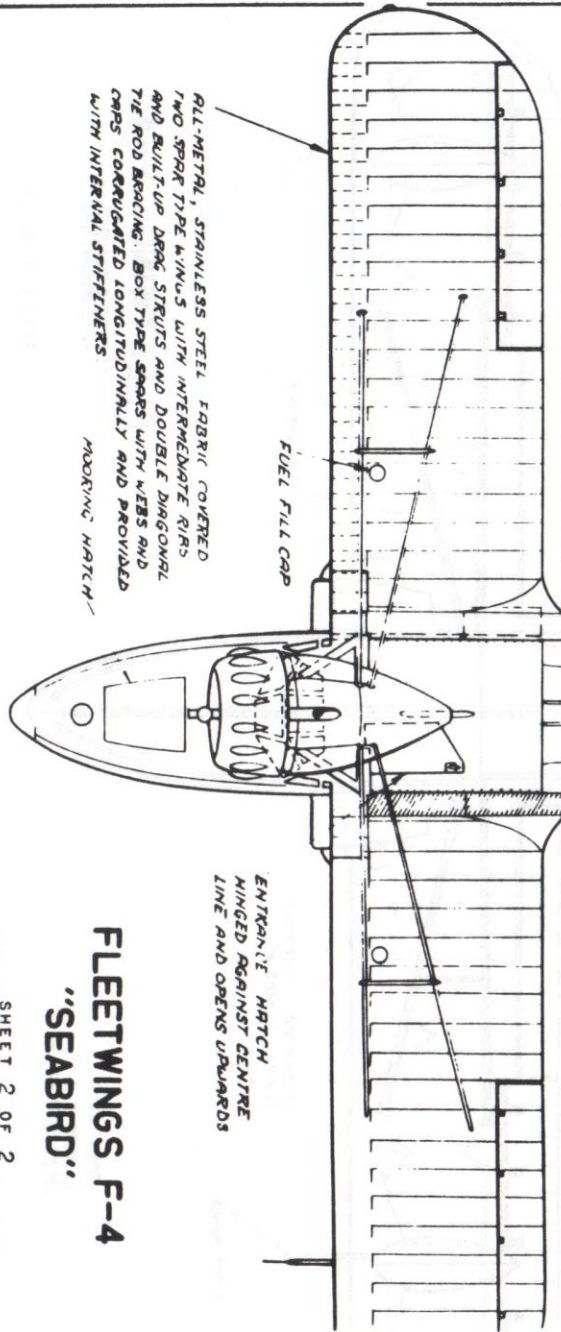
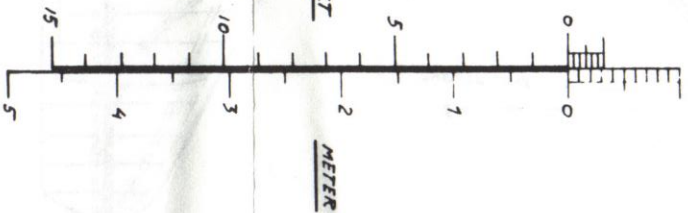
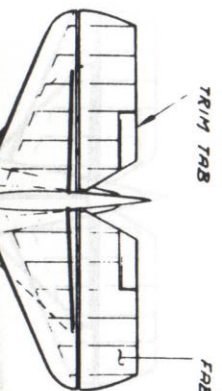

ALL-METAL, STAINLESS STEEL FABRIC COVERED
TWO SPAR TYPE WINGS WITH INTERMEDIATE RIBS
AND BUILT-UP DRAG STRUTS AND DOUBLE DIAGONAL
TIE ROD BRACING. BOX TYPE SPARS WITH WEBS AND
CAPS CORRUGATED LONGITUDINALLY AND PROVIDED
WITH INTERNAL STIFFENERS

HOODING HATCH

FLEETWINGS F-4 "SEABIRD"

SHEET 2 OF 2

SCALE= 1:34 (3/16" = 1'0")